



**TORQTAPER® PLUS
HELICAL SHAFT MOUNT SPEED
REDUCERS TORQUE ARM KIT**

FORM

**8920E
Revised
April 2015**

⚠ WARNING

- Read and follow all instructions carefully.
- Disconnect and lock-out power before installation and maintenance. Working on or near energized equipment can result in severe injury or death.
- Do not operate equipment without guards in place. Exposed equipment can result in severe injury or death.
- Removing torque arm when load is applied to gearbox can cause severe injury or death. The motor and gearbox must be properly secured and load removed before assembly or disassembly of the torque arm or components.

⚠ CAUTION

- Periodic inspections should be performed. Failure to perform proper maintenance can result in premature product failure and personal injury.

Top Motor Mount:

The Torque Arm Brackets (Item# 6) mount in either Position 1 or Position 2 (shown in Figure 1). Remove the housing flange Bolts / Nuts (Item# 9) and attach the torque arm brackets to the gearbox. (Do not reinstall flat washers on the bolts).

CAUTION: The Torque Arm Brackets may be flat or bent depending on the reducer size. The flat brackets are symmetrical and can be mounted in either orientation. The bent Brackets must be mounted as shown in the Figure 2. The Brackets for the 107 and 315 reducers must be mounted as shown in Figure 2 Option 2. The Brackets for the 215 and 307 reducers must be mounted as shown in Figure 2 Option 3.

Tighten the flange Bolts / Nuts (Item# 9) to the recommended torque as shown in Table 2.

Thread the Jam Nut - Right Hand Threads (Item# 4) onto the Rod End - Right Hand Threads (Item# 2), and then thread this rod end into the Turnbuckle (Item# 1). Thread the Jam Nut - Left Hand Threads (Item #8) onto the Rod End - Left Hand Threads (Item #3), and then thread this rod end into the opposite end of the turnbuckle.

CAUTION: Both rod ends must extend into the opening of the turnbuckle a minimum of 1/2 inch during installation and when the gearbox is operating.

Mount the reducer to the shaft following the procedures as described in the installation instructions for the reducer and bushing kits.

Bolt the Torque Arm Foot (Item# 7) to a rigid foundation. (Foot bolts are customer supplied Grade 5 or stronger). Note: The torque arm foot must be in-line with torque arm brackets within 1/2 inch per foot of torque arm length.

CAUTION: Mount the torque arm foot in a location such that the torque arm is in tension when the gearbox is operating under load. The torque arm foot in Figure 1 is correctly mounted for a clockwise output shaft rotation. A counter-clockwise rotation of the output shaft requires mounting the torque arm foot to the right side of the mounting brackets.

Figure 1

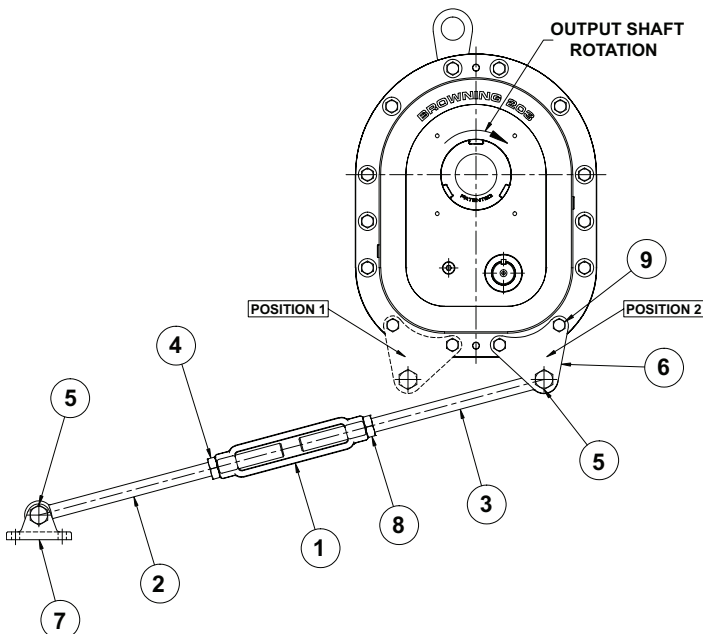

Figure 2

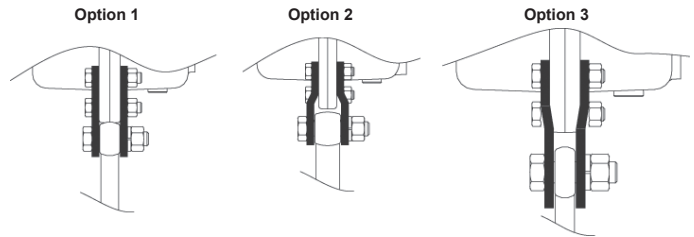

Table 1 Torque Arm Kit Parts List

Item	Quantity	Description
1	1	Turnbuckle
2	1	Rod End – Right Hand Threads
3	1	Rod End – Left Hand Threads
4	1	Jam Nut – Right Hand threads
5	2	Bolts / Lockwashers / Nuts
6	1 Pair	Torque Arm Brackets
7	1	Torque Arm Foot
8	1	Jam Nut – Left Hand Threads
9	2, 3 or 4	Bolts / Nuts

Install the torque arm between the torque arm brackets and the torque arm foot using the supplied Bolts / Lockwashers / Nuts (Item# 5). Before installing the lockwashers and nuts apply a thread lock compound to the bolts. Install lockwashers and nuts, tighten the nuts.

A line through the hollow output shaft and the center of the torque arm bracket must be at an angle of 90° to the centerline of the torque arm within 30° (as shown in Figure 1).

Adjust the turnbuckle to position the gearbox in the correct position, and then tighten both jam nuts against the turnbuckle.

Reverse Load Mounting:

Two torque arms are installed so that one or the other of the torque arms is in tension for either direction of loading. Figure 3 shows this mounting arrangement.

Figure 3

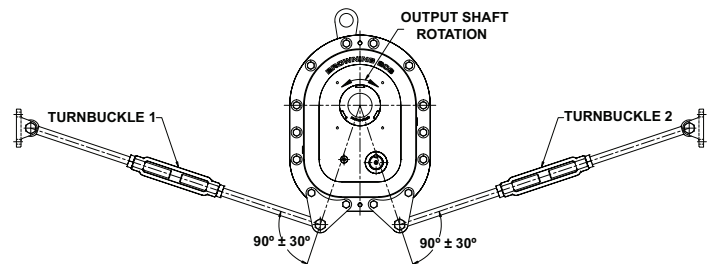

Install the torque arm at Position 1 as described in "Standard Mounting" Mount the second torque arm and tighten the turnbuckle by hand until clearance is eliminated from torque arm assemblies. Rotate turnbuckle 2 an additional one-quarter turn tighter and tighten jam nuts on both torque arm 1 and 2.

A Regal Brand

REGAL

Table 2 Bolt Torque Specifications

Reducer Size	Flange Bolt		Foot to Foundation		CUSTOMER SUPPLIED GRADE 5 MINIMUM
	Bolt Size	Ft-Lbs	Bolt Size		
107	5/16-18	16	3/8-16		
115	3/8-16	25	3/8-16		
203	7/16-14	40	3/8-16		
207	1/2-13	65	7/16-14		
215	1/2-13	65	7/16-14		
307	5/8-11	125	1/2-13		
315	5/8-11	125	5/8-11		
407	5/8-11	125	5/8-11		
415	3/4-10	220	3/4-10		
507	3/4-10	220	3/4-10		
608	3/4-10	220	1-8		
800	1-8	525	1 1/4-7		

Side Motor Mount:

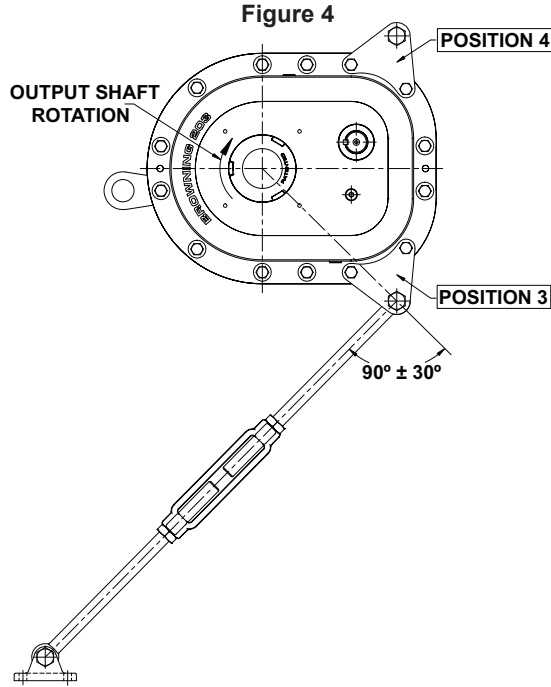

Position 3 or Position 4, as shown in Figure 4, is required for side mounting of a motor mount kit to provide clearance for the motor mount supports.

Belt Tensioning Mounting:

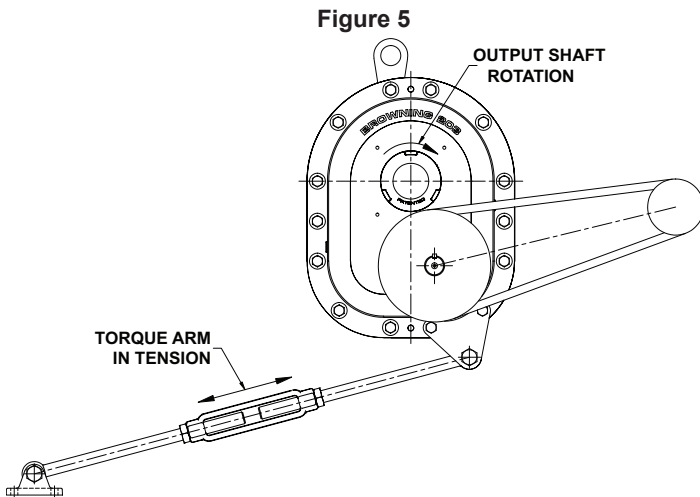

The mounting configuration, as shown in Figure 5, uses the torque arm for adjustment of the belt drive.

Mount the torque arm as described in "Standard Mounting."

Locate the centerline of the belt drive within 30 degrees of the centerline of the torque arm and on the opposite side (as shown in Figure 5).

Using the torque arm, adjust the belt tension per the belt manufacturer's instructions.

Notice: Sheaves for the input shaft of the reducer must not be smaller than the diameter shown in the selection table from which the reducer was selected. Smaller diameter sheaves may result in reduced bearing life.

Remove housing flange bolts and attach torque arm brackets to gearbox using bolts supplied in the torque arm kit.

Tighten the flange bolts to the recommended torque as shown in Table 1.

Compression Mounting:

Application limited to light shock loading and/or reversing loads not exceeding catalog ratings. Applications with medium shock loading and full reversing loads use the reverse load mounting as shown in Figure 3. This Compression Mounting method requires more precise mounting alignment and reduced torque arm length adjustment.

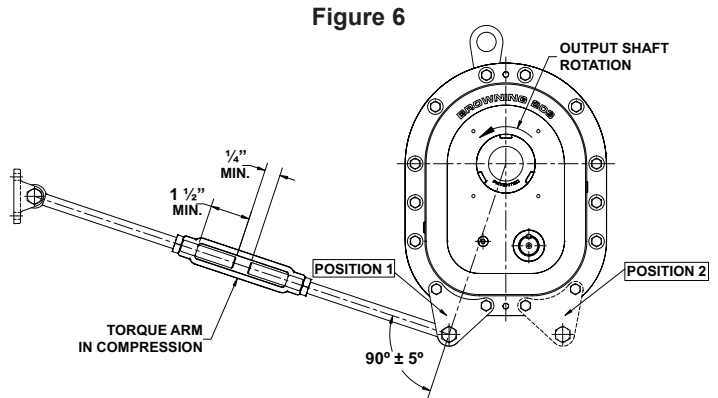

Thread the right handed jam nut onto the rod end with the right handed threads, then thread this rod end into the turnbuckle. Thread the left handed jam nut onto the rod end with the left handed threads. Thread this left handed rod end into the turnbuckle on the end with the left handed threads.

CAUTION: Both rod ends must extend into the opening of the turnbuckle a minimum of 1.50 inches on each end at installation when gearbox is operating. Maintain a minimum of 1/4 inch between rod ends.

Mount the reducer to the shaft following the procedures as described in the installation instructions for the reducer and bushing kits.

Bolt the torque arm foot to a rigid foundation. Use the heavy duty flat washers supplied with the torque arm kit. Confirm the foundation or frame will withstand the loads. (Foot bolts are customer supplied and must be Grade 5 or stronger).

Notice: The torque arm foot must be mounted in line with the torque arm brackets within 1/4 inch per foot of the torque arm length.

Install the torque arm between the torque arm brackets and the torque arm foot using the supplied bolts. Before installing the lockwashers and nuts, apply a thread lock compound to the bolts. Install lockwashers and nuts, tighten the nuts. A line through the hollow output shaft and the center of the torque arm bracket must be at an angle of 90 degrees to the centerline of the torque arm within 5 degrees (as shown in Figure 6).

Adjust the turnbuckle to position gearbox, then tighten both jam nuts against the turnbuckle. (Note: Each rod end must extend a minimum of 1.50 inches into the opening in the turnbuckle.)

A Regal Brand

